

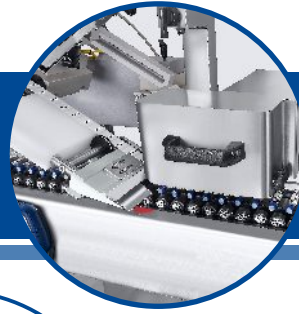

HORIZONTAL AMPULE LABELER

CVC 352



The CVC 352 Horizontal Ampule Labeler is built to automatically apply pressure sensitive labels onto round containers that will not convey upright on a conveyor. The CVC 352 comes with a roller chain conveyor and can be purchased with an optional product loader. The CVC 352 is an ideal machine for contract packagers and manufacturers serving the biotech, nutraceutical, cosmetic, and personal care markets.

All CVC labelers include our patented Self Set™ software which utilizes a high frequency encoder for extremely easy setup and wrinkle free labeling at the touch of a button.

STANDARD FEATURES

- Siemens control system
- Siemens HMI touch screen
- Stainless steel frame on lockable casters
- Stainless steel flatbed conveyor with table top chain
- Servo motor control
- Label head with up to ±1 mm accuracy
- Compact design, available with both on-line and off-line operations.
- Type 304 stainless steel construction
- ISO 9001 : 2015 certified



AVAILABLE OPTIONS

- ▲ Ampoule/Vial Loading Cassette
- ▼ Vertical Loading System



CVC 352 Technical Specifications

Speed	Up to 300 Bottles per minute (BPM) (subject to our trial confirmation)
Bottle Height	Configurable from 1 5/8" to 2 3/4" (40 mm - 70 mm)
Bottle Diameter	Configurable from 3/8" to 1" (10 mm - 24 mm) dependent on conveyor width
Label Width / Height	Configurable from 5/8" to 3 3/4" (15mm - 96mm) dependent on label head type
Label Length	5/8" to 3" (15mm - 75mm)
Label Roll	Max 14" (356mm) outside diameter with 3" (76mm) core
Conveyor Width	Configurable up to 5 5/8" (144mm) / 7 5/8" (194mm)
Conveyor Length	Standard 63 3/4" (1620mm) (Extendable)
Power	220V, single phase, 1100 VA (5 Amp)
Air Pressure	6 bar (87 psi) (ISO 8573-1)
Air Consumption	78.5 NLit/m (2.8cfm) (for optional reject and Lot/Date printer)
Machine Dimension	9'-4" x 6'-2" x 6'-2" (2,850 mm x 1,885 mm x 1,890 mm) (L x W x H)
Machine Weight	605 kg (1334 lbs)
Noise Level	70~75 dB

TECHNICAL SPECIFICATIONS

AVAILABLE OPTIONS

- C70 Hot Stamp (Lot/Date Coding)
- Missing Hot Stamp Imprint Check
- Integrated Thermal Printer (Lot/Date, Bar Code and Graphics)
- Dataflex or Similar Lot/date Code Printer
- Clear , Metallic or Color Label Sensor
- Product Loader
- Adjustable Tilt for Tapered Bottles
- Custom made Wrap Station
- Automatic Vertical Stand-up Accumulation System
- Camera Detection (OCV System)
- Missing Label Detection System (UV)
- Rejection System
- Rejection System Verification Check
- 3-Color Tower Stack Light
- 21CFR Part 11 Compliance
- OPC UA for Data Collection



Integrated Thermal Printer

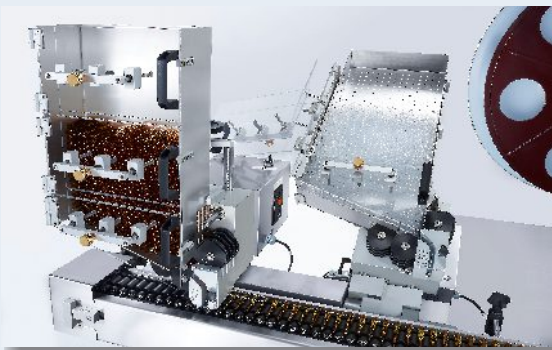

Ampoule/vial loading cassette can be refilled while the machine is running

MACHINE LAYOUTS

Top View

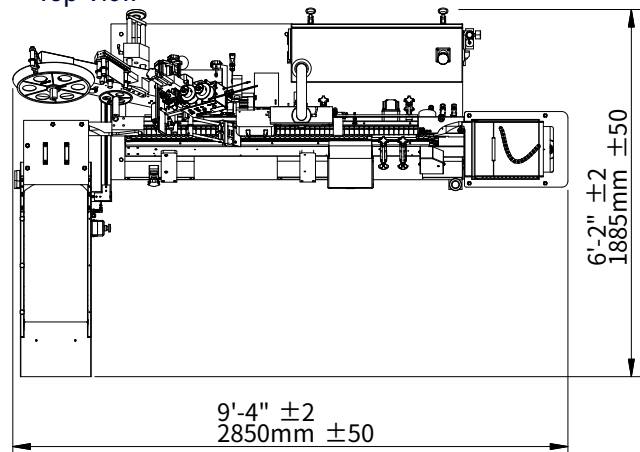

Front View

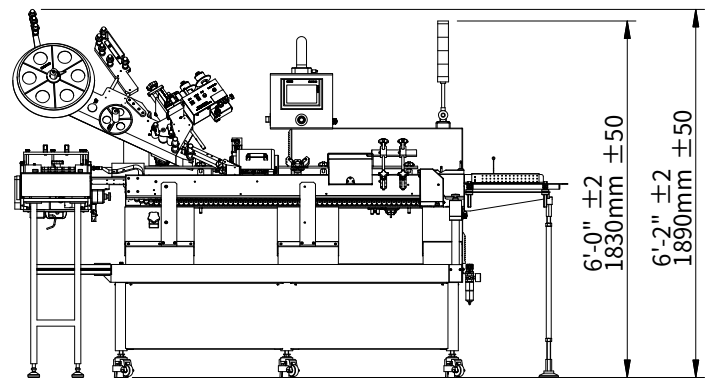

The dimensions shown are for standard machine. The conveyor can be extended: the length may vary based on selected options. This machine can run independently or be integrated into an automated packaging line. All CVC equipment is covered by a one-year parts warranty. Full Warranty details are included in our equipment proposals.



Contact Us

USA
10861 Business Drive, Fontana, CA 92337
Phone: +1 (909) 355-0311
www.cvctechnologies.com
sales@cvcusa.com

USA East Coast Office
1855 New Highway, Suite C, Farmingdale NY 11735
sales@cvcusa.com

Taiwan-Asia Pacific Headquarters
Phone: +886 (4) 2496-3666
sales@cvctechnologies.com

China/India
sales@cvctechnologies.com