

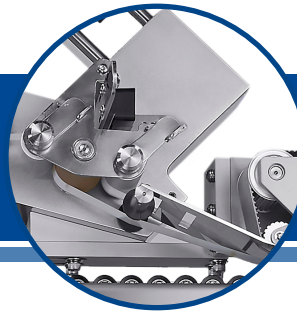

# HORIZONTAL AMPULE LABELER

## CVC 350.U2



The CVC 350.U2 Horizontal Wrap Labeler is built to automatically apply pressure sensitive labels onto round containers that will not convey upright on a conveyor. The 350.U2 comes with a roller chain conveyor and can be purchased with an optional product loader. The 350.U2 is an ideal machine for contact packagers and manufacturers serving the biotech, nutraceutical, cosmetic, and personal care markets.

### STANDARD FEATURES

- SelfSet™ Auto Adjusting Control System
- Servo Motor Driven Head Labeling
- Touch Screen HMI
- Label Head with up to  $\pm 1$  mm ( $1/32$ " ) Accuracy (\*Bottles/ Containers Dependent)
- Label Sensor for Paper or Opaque Labels
- Product Sensor with Opaque and Clear Bottle Mode
- Stainless Steel Frame on Lockable Casters
- Stainless Steel 25-Degree Conveyor with 5-5/8" Wide Roller Chain

3-color Tower Lamp ▶  
(option)



### CVC 350 Technical Specifications

Type	U2
Productivity	Up to 250 BPM (subject to trial confirmation) Labeling Speed: 38 M/min (124 ft/min)
Applicable Size	Label: Length: 15-75 mm ( $1/2$ " to 3") Width: (depend on label head type) A: 15-39 mm ( $1/2$ " to $1\ 1/2$ " ) B: 15-96 mm ( $1/2$ " to $3\ 3/4$ " ) Bottle: Dia.: $\varnothing$ 10-24mm ( $3/8$ " to 1") (depend on conveyor width) Height: Type A: 40-70 mm ( $1\ 1/2$ " to $2\ 3/4$ " ) Type B: 40-120mm ( $1\ 1/2$ " to $4\ 3/4$ " )
Power Source	110/220 V, 50/60 HZ, 1 PH
Power Consumption	748 VA (110V: 6.8 A, 220V: 3.4 A)
Air Pressure	6 bar (87 psi)
Air Consumption	50 NL/min (1.8 CFM) (for optional Lot/Date printer)
Machine Dimensions ( L x W x H )	1,931 x 840 x 1,738 mm (6'-4" x 2'-9.1" x 5'-8.4")
Machine Weight	230 kg (507 lbs)
Noise Level	$\leq 75$ dB

Technical data contained in this material are not binding and may be subject to change without prior notice.

# TECHNICAL SPECIFICATIONS

## AVAILABLE OPTIONS

- Vertical Bottle Loading System
- C60 Hot Stamp Printer
- Clear Label Sensor
- Missing Imprint Inspection
- Missing Label on Bottle Inspection
- Bottle Loading Device
- Bottle Reject System
- Bottle Reject Verification Check
- 3-color Tower Lamp
- Vertical Bottle Accumulation System
- Bottle Backlogged Sensor



## MACHINE LAYOUTS

### Top View

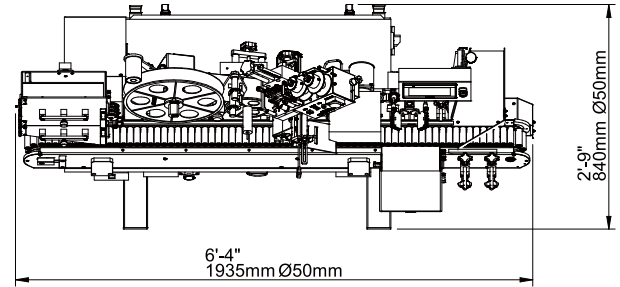

### Front View

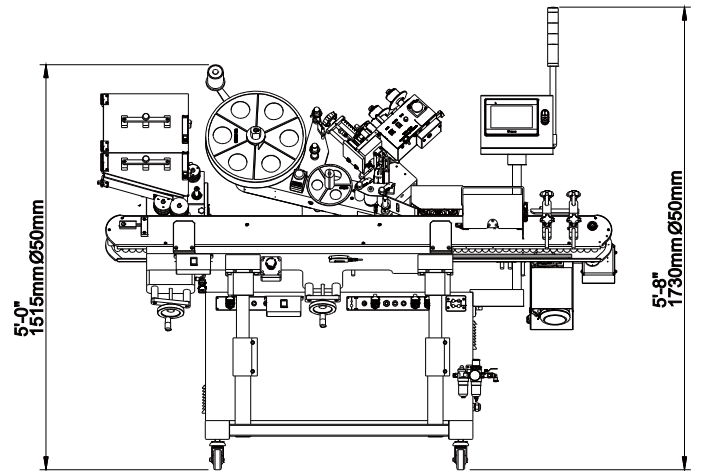

Technical data contained in this material are not binding and may be subject to change without prior notice.



## Contact Us

### USA

10861 Business Drive, Fontana, CA 92337  
Phone: +1 (909) 355-0311  
[www.cvcusa.com](http://www.cvcusa.com) ; [www.cvctechnologies.com](http://www.cvctechnologies.com)  
[sales@cvcusa.com](mailto:sales@cvcusa.com)

### Taiwan-Asia Pacific Headquarters

Phone: +886 (4) 2496-3666  
[sales@cvctechologies.com](mailto:sales@cvctechologies.com)

### India

Phone: +91 (22) 2562-1242, +91 (22) 2562-1243  
[sales@cvctechologies.com](mailto:sales@cvctechologies.com)

### China

Phone: +86 (512) 8363-6368  
[sales@cvctechologies.com](mailto:sales@cvctechologies.com)